

5. START-UP

5.1. CONNECTION TO ELECTRONIC CONTROL UNIT

Warning: Always turn off the electricity supply before carrying out any work on the electronic control unit (connections, programming, maintenance).

Warning: When terminal board J2 is disconnected, high voltage remains on the outputs of the capacitor, motor and transformer power supplies.

Observe points 10, 11, 12, 13 and 14 in the GENERAL SAFETY INSTRUCTIONS.

As shown in Fig. 2, prepare the conduits and make the electrical connections from the 826 MPS electronic control unit to the chosen accessories.

Always route the power supply cables separately from the control and safety cables (keyswitch, receiver, photocells, etc.). Use separate conduits to avoid any interference.

TABLE 2 TECHNICAL CHARACTERISTICS OF 826 MPS

POWER SUPPLY	230 V (+6 -10%) 50 Hz
MAX. MOTOR LOAD	600 W
MAX. ACCESSORIES LOAD	500 mA
MAX. WARNING LAMP POWER	5 W (24Vac)
TEMPERATURE RANGE	- 20°C + 55°C

TABLE3 ACCESSORIES CURRENT DRAW

TYPE OF ACCESSORY	NOMINAL CURRENT DRAW
R 31	50mA
PLUS 433 E	20mA
MINIDEC SL / DS	6mA
DECODER SL / DS	20mA / 55mA
RP 433 ESL / EDS	12mA / 6mA
DIGICARD	15mA
METALDIGIKEY	15mA
FOTOSWITCH	90mA
DETECTOR F4 / PS6	50mA
MINIBEAM	70mA

5.1.1. 826 MPS CONTROL UNIT

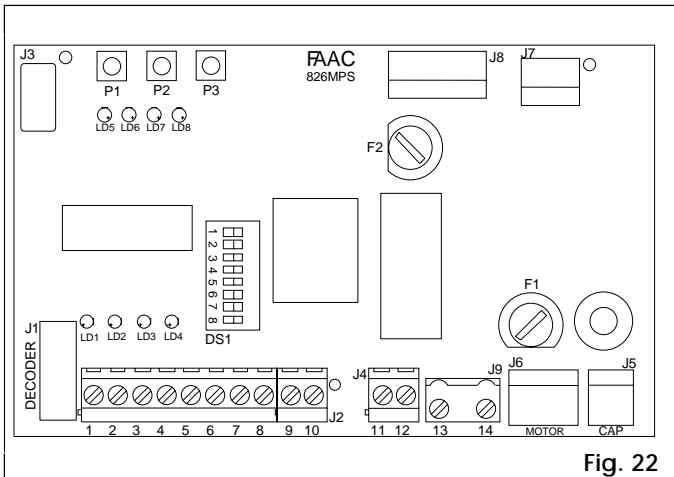

Fig. 22

Table 4 826 MPS control unit components

LD1	OPEN LED
LD2	PARTIAL OPEN/CLOSE LED
LD3	STOP LED
LD4	SAFETY LED
LD5	LIMIT SWITCH ALARM LED
LD6	OPENING LIMIT SWITCH LED
LD7	CLOSURE LIMIT SWITCH LED
LD8	SLIDING SPEED LED
P1	OPENING LIMIT SWITCH PROGRAMMING BUTTON
P2	CLOSURE LIMIT SWITCH PROGRAMMING BUTTON
P3	LIMIT SWITCH / RESET PROGRAMMING BUTTON
J1	DECODER CONNECTOR
J2	LOW VOLTAGE TERMINAL BLOCK
J3	ADL CONNECTOR
J4	FAAC LAMP OUTPUT TERMINAL BLOCK
J5	CAPACITOR CONNECTOR
J6	ELECTRIC MOTOR CONNECTOR
J7	TRANSFORMER PRIMARY CONNECTOR
J8	TRANSFORMER SECONDARY CONNECTOR
J9	230 Vac POWER SUPPLY TERMINAL STRIP
F1	ELECTRIC MOTOR FUSE (F 5 A)
F2	ACCESSORIES FUSE (T 1.6 A)
DS1	PROGRAMMING DIPSWITCH

5.1.2. ELECTRICAL CONNECTIONS

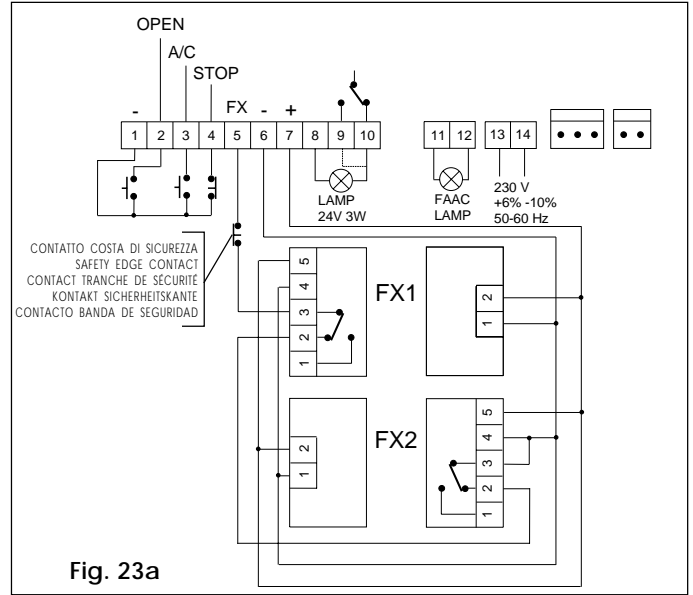

Fig. 23a

5.2. DESCRIPTION OF TERMINAL BLOCK

5.2.1. OPEN (terminals 1-2)

This means any control device with a **N.O.** contact which causes the gate to open when activated. In automatic and semiautomatic logics it is active for both opening and closure.

5.2.2. A/C (terminals 1-3)

This means any control device with a **N.O.** contact which causes partial opening of the gate when activated in E1, E2, A1, A2, S1 and S2 logics. In B and C logics it causes the gate to close.

5.2.3. STOP (terminals 1-4)

This means a control device with a **N.C.** contact which causes the gate status (opening-pause-closure) to be interrupted until the next impulse is sent.

N.B.: If stop devices are not connected, jumper terminals 1-4.

5.2.4. SAFETY FX (terminals 5 - 6)

This means all devices (photocells, safety edges, magnetic loops) with a **N.C.** contact which stop the movement of the gate when an obstacle is present in the area protected by the safety devices.

N.B.: If stop devices are not connected, jumper terminals 5-6.

5.2.5. + - LOW VOLTAGE POWER SUPPLY (terminals 6 - 7)

These are the 24 Vdc terminals to which the accessories must be connected.

Proceed as shown in Table 3 in order not to exceed the maximum permitted load.

5.2.6. LAMP (terminals 8 - 9 - 10)

These are the 24 Vac terminals to which the warning lamp must be connected.

Warning lamp operation illustrated in Fig. 24 refers to connection to terminals 8-9. Connecting the warning lamp to terminals 8-10 gives inverse operation.

5.2.7. FAAC LAMP (terminals 11 - 12)

These are the 230 Vac terminals to which the flashing light must be connected.

5.2.8. 230 V MAINS SUPPLY (terminals 13 - 14)

These are the terminals to which the 230 Vac electricity supply must be connected.

Connect the earth cable to the post as shown in Fig. 23b.

5.2.9. BEHAVIOUR OF SAFETY DEVICES

The safety devices operate during closure only. In A1, E1 and S1 logics, interrupting the safety device contacts causes the gate to stop closing and start opening immediately. In

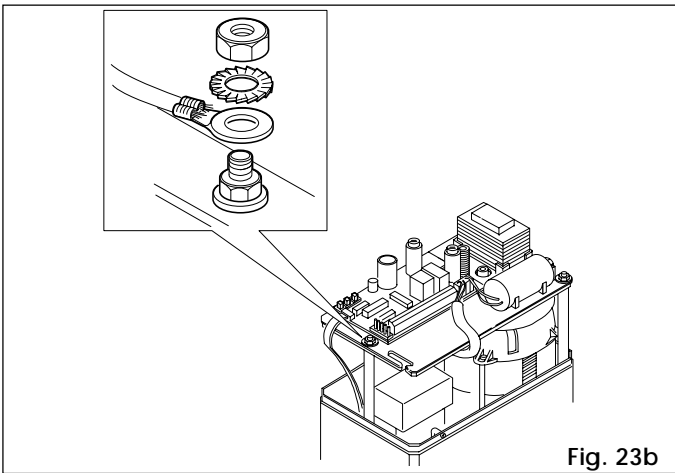

Fig. 23b

A2, E2 and S2 logics interrupting the safety device contacts causes the gate to stop closing, then to start opening again when the safety devices are released.

5.2.10. ELECTRONIC SAFETY DEVICE

(models 820 EMC - 860 EMC only)

The operator is equipped with a system which cuts in when it senses a 20% reduction in pinion speed. The device inverts the closing movement and inhibits opening movement. When this safety device cuts in, LED S goes out for a few seconds. Automatic re-closure is inhibited if the electronic anti-crushing safety has cut in.

5.3. DIPSWITCH SETTINGS

N.B.: PRESS THE RESET BUTTON AFTER ALL PROGRAMMING OPERATIONS

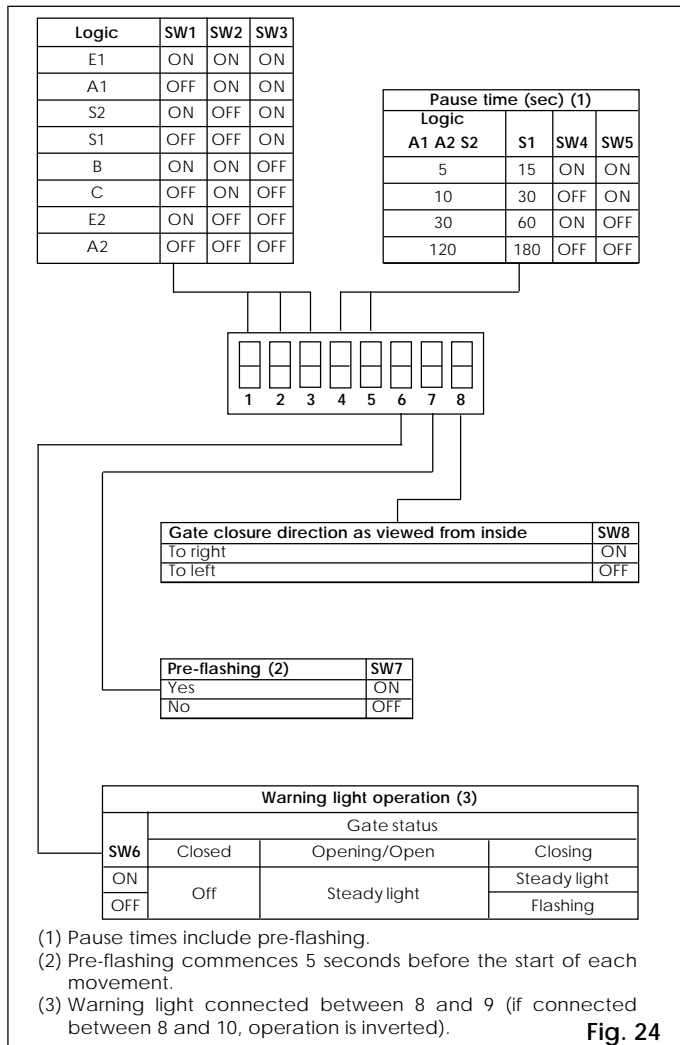

Fig. 24

5.4. OPERATION IN VARIOUS LOGICS

TABLE 5 LOGIC E1 (SEMI-AUTOMATIC)

LOGIC E1	IMPULSES			
	GATE STATUS	OPEN - A/C (1) -	STOP	SAFETY
CLOSED	opens (2)	no effect	no effect	no effect
OPEN	recloses (2)	no effect	no effect	no effect
CLOSING	inverts motion	stops	stops	inverts motion
OPENING	stops	stops	stops	no effect
STOPPED	recloses (reopens when safety devices are engaged) (2)	no effect	no effect	no effect

TABLE 6 LOGIC E2 (SEMI-AUTOMATIC)

LOGIC E2	IMPULSES			
	GATE STATUS	OPEN - A/C(1)-	STOP	SAFETY
CLOSED	opens (2)	no effect	no effect	no effect
OPEN	recloses (2)	no effect	no effect	no effect
CLOSING	inverts motion	stops	stops	stops and inverts motion when disengaged (2)
OPENING	stops	stops	stops	no effect
STOPPED	recloses (reopens when safety devices are engaged) (2)	no effect	no effect	no effect

TABLE 7 LOGIC A1 (AUTOMATIC)

LOGIC A1	IMPULSES			
	GATE STATUS	OPEN - A/C (1) -	STOP	SAFETY
CLOSED	opens and recloses after pause time (2)	no effect	no effect	no effect
OPEN	recloses after 5 s (3)	stops counting	stops counting	freezes pause until disengagement
CLOSING	inverts motion	stops	stops	inverts motion
OPENING	no effect	stops	stops	no effect
STOPPED	recloses (2)	no effect	no effect	no effect

TABLE 8 LOGIC A2 (AUTOMATIC)

LOGIC A2	IMPULSES			
	GATE STATUS	OPEN - A/C (1) -	STOP	SAFETY
CLOSED	opens and recloses after pause time (2)	no effect	no effect	no effect
OPEN	recloses after 5 s (3)	stops counting	stops counting	recloses after 5 s
CLOSING	inverts motion	stops	stops	stops and inverts motion when disengaged (2)
OPENING	no effect	stops	stops	no effect
STOPPED	recloses (2)	no effect	no effect	no effect

TABLE 9 LOGIC S1 (SAFETY)

LOGIC S1	IMPULSES			
	GATE STATUS	OPEN - A/C (1) -	STOP	SAFETY
CLOSED	opens and recloses after pause time (2)	no effect	no effect	no effect
OPEN	recloses immediately (2 and 3)	stops counting	stops counting	recloses after 5 s
CLOSING	inverts motion	stops	stops	inverts motion
OPENING	inverts motion	stops	stops	no effect
STOPPED	recloses (2)	no effect	no effect	no effect

TABLE 10 LOGIC S2 (SAFETY)

LOGIC S2	IMPULSES			
	GATE STATUS	OPEN - A/C (1) -	STOP	SAFETY
CLOSED	opens and recloses after pause time (2)	no effect	no effect	no effect
OPEN	recloses immediately (2 and 3)	stops counting	stops counting	freezes pause until disengagement
CLOSING	inverts motion	stops	stops	stops and inverts motion when disengaged (2)
OPENING	inverts motion	stops	stops	no effect
STOPPED	recloses (2)	no effect	no effect	no effect

TABLE 11 LOGIC B (SEMI-AUTOMATIC)

LOGIC B	IMPULSES				
	GATE STATUS	OPEN	A/C (5)	SAFETY (until disengagement)	STOP
CLOSED	opening (2)	no effect	no effect	no effect	no effect
OPEN	no effect	closing (2)	inhibits closing	inhibits closing	no effect
CLOSING	no effect	no effect	stops	stops	stops movement
OPENING	no effect	no effect	no effect	no effect	stops movement
STOPPED	completes opening (2)	completes opening (2)	inhibits closing	inhibits closing	no effect

TABLE 12 LOGIC C (DEADMAN)

LOGIC C	IMPULSES				
	GATE STATUS	OPEN (4)	A/C (4 and 5)	SAFETY (until disengagement)	STOP
CLOSED	opens	no effect	no effect	no effect	no effect
OPEN	no effect	closes	inhibits closing	no effect	no effect
CLOSING	no effect		stops	stops	
OPENING		no effect	no effect	stops	
STOPPED	completes opening	completes closing	inhibits closing	no effect	

- (1) The A/C input enables partial opening.
- (2) With pre-flashing selected movement starts after 5 seconds.
- (3) If the impulse is sent after pre-flashing the timer recounts.
- (4) For operation in C logic keep the pushbutton depressed. Movement stops upon release.
- (5) The A/C input controls closure.

5.5. PROGRAMMING LIMIT SWITCHES

IMPORTANT: CHECK THE LENGTH OF THE GATE. THE OPERATOR HAS A LIMIT SWITCH SYSTEM WHICH ALLOWS FOR AUTOMATION OF GATES WITH A MAXIMUM LENGTH OF 13 m FOR MODELS 820 (Z 20 PINION) AND 10 m FOR MODELS 860 (Z 16 PINION).

FAILURE TO OBSERVE THESE RECOMMENDATIONS WILL ADVERSELY AFFECT OPERATION OF THE ADL LIMIT SWITCH.

- 1) To facilitate installation, it is advisable to program the control unit in E1 logic (semi-automatic) by positioning the relative dipswitches as follows:

SW1 - SW2 - SW3 to ON.

It is also advisable to inhibit pre-flashing by positioning dipswitch SW7 to OFF.

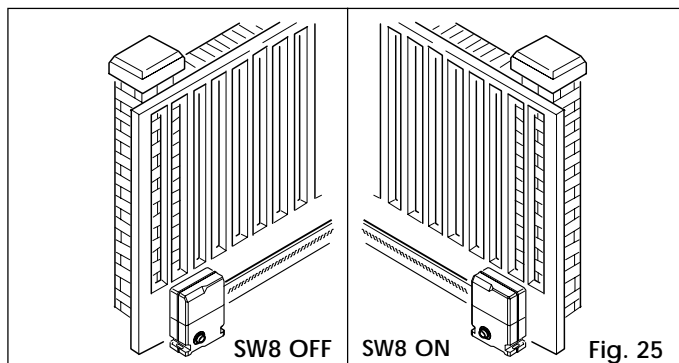

- 2) Position dipswitch SW8 according to the direction in which the gate closes (see Fig. 25) (Rack application).

IMPORTANT: In chain applications the dipswitch SW8 must be positioned to ON for closure to left and OFF for closure to right.

The positions of dipswitches SW4, SW5 and SW6 have no effect.

- 3) Move the gate manually to its mid-travel position.
- 4) Switch on the electricity supply to the system and check that the status of the LEDs is as follows:

LED ON	LED OFF
ADL - FCA - FCC S (860) - STOP - FSW	OPEN - A/C - S (820)

IMPORTANT: MAKE SURE THAT THE GATE IS AT ITS MID-TRAVEL POSITION.

- 5) Remove the safety tab as illustrated in Fig. 26 and keep it for future maintenance work.
- 6) Open the gate until it is just a few centimetres away from the open position end stop.

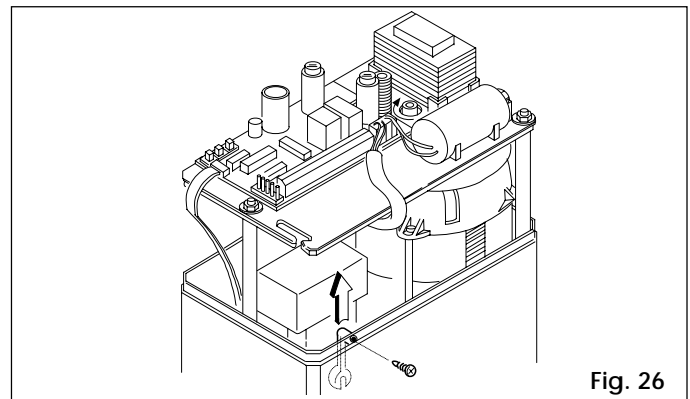

Fig. 26

- 7) Without moving the gate carry out the following operations on the 826 MPS control unit (Fig. 27) in the stated order:

- a) hold down FCA.
- b) press the RESET button for about 1 second. The ADL LED will light up for approximately one second to confirm that the limit switch has been recognised.
- c) release the FCA button.

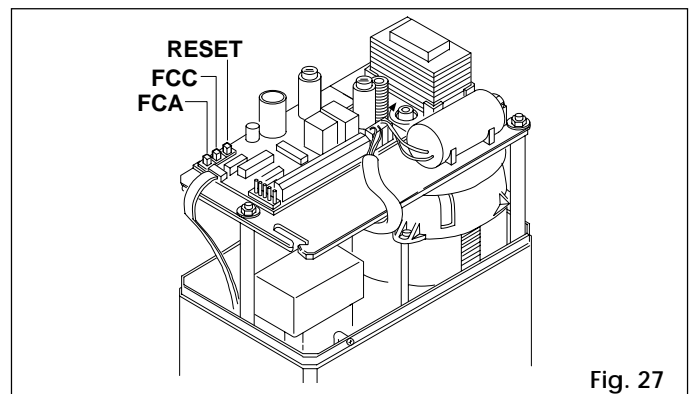

Fig. 27

- 8) Wait for a few seconds, then slide the gate manually until it is a few centimetres from the closed position end stop.
- 9) Without moving the gate carry out the following operations on the 826 MPS control unit (fig. 27) in the stated order:
 - a) hold down FCC.
 - b) press the RESET button for about 1 second. The ADL LED will light up for approximately one second to confirm that the limit switch has been recognised.
 - c) release the FCC button.
- 10) Re-engage the operator by sliding the gate until the release device engages.
- 11) Send an open impulse and check that the gate opens, performs a brief deceleration, then stops at the programmed open position limit switch.
- 12) Send another impulse and check that the gate closes.
- 13) To modify limit switch settings, repeat the sequence of operations from point 3) to point 12).

IMPORTANT: If the LED starts flashing quickly (0.25 s) during the limit switch setting operations, follow the instructions given in the **ALARM CONDITIONS** section.

N.B.: Any interruption in the power supply will not affect memorisation of the limit switch positions.

If during a manual operation the gate is moved beyond the memorised limit switch positions, a series of open impulses must be sent to move the gear motor to the zone of normal operation.